

El Conquistador de Montañas *“The Conqueror of the Mountains”*

Our high performance, full suspension off-road tandem, El Conquistador de Montañas, is the culmination of Ventana’s superior design capabilities and skilled manufacturing execution, and is a work of beauty besides. To produce this trailblazing tandem we paired Ventana’s trademark rear suspension technology with an ultra-stiff mainframe. The vertically positioned rear shock contributes to El Conquistador’s stable platform and superior handling performance.

El Conquistador de Montañas is ready for captains and stokers to join forces and capture the mountain

Frame Size (Dimensions in inches except as noted)								
Item	17/14	17/16	19/14	19/16	19/18*	21/14*	21/16*	21/18*
A1	17.0	17.0	19.0	19.0	19.0	21.0	21.0	21.0
A2	15.0	16.6	15.0	16.6	18.6	15.0	16.6	18.6
B1	22.1	22.1	23.0	23.0	23.0	24.0	24.0	24.0
B2	30.5	30.5	30.5	30.5	30.5	30.5	30.5	30.5
C	4.00	4.00	4.75	4.75	4.75	5.50	5.50	5.50
D	71.4	71.4	72.4	72.4	72.4	73.2	73.2	73.2
E	17.0	17.0	17.0	17.0	17.0	17.0	17.0	17.0
F	27.4	28.3	28.1	29.1	30.2	27.4	28.6	31.2
G	29.8	29.3	32.5	32.5	32.5	33.9	33.9	33.9
H, I1, I2	72°	72°	72°	72°	72°	72°	72°	72°
J	41mm	41mm	41mm	41mm	41mm	41mm	41mm	41mm
K	471mm	471mm	471mm	471mm	471mm	471mm	471mm	471mm

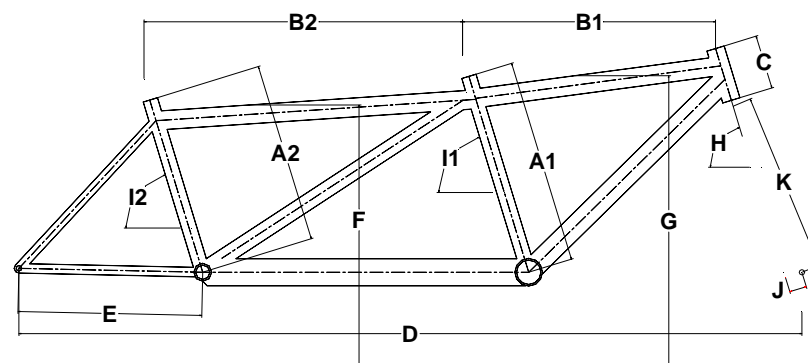

Note: Drawing for dimensional reference only

*Semi-custom sizes (extra charge)

- Handcrafted in-house by Ventana
- Legendary Ventana “Electric Sex” TIG welds
- Oversize straight gage tubing
- Heavy duty, maximum lateral stiffness Ventana exclusive quad bearing package at every pivot
- 4” rear travel with Fox RP23 air shock
- 100mm fork compatibility
- High aspect ratio rocker for increased cornering stiffness
- International standard disc brake mount
- 1-1/8” internally butted head tube with wrap-around gusset
- Fits 34.9 mm top pull front derailleur
- 27.2 mm seat post diameters
- BB shell width: 68 mm captain, 73 mm stoker
- Colors: Candy Blue, Candy Red, Super Dust, Grinch Green or Cosmic Orange
- Options/upgrades: 5” travel, custom & semi-custom geometry

Ventana Mountain Bikes, USA

P.O. Box 39, Rancho Cordova, CA 95741 Phone: 916-631-0544 Fax: 916-631-7627 Web site: www.ventanausa.com E-mail: info@ventanausa.com

Designed and hand built in California by people who ride